



Aviation  
home

Specialist in Selling Light  
Aircrafts & Spare Parts



QUALITY AIRCRAFT SINCE 1948  
**TECNAM**

*P92 Tail Dragger*

# P92 TailDragger



'Tail Dragger' is the very latest and special edition of Tecnam P92 series of aeroplanes.

With the Tecnam P92 celebrating its 20th anniversary and with over 2500 P92 aeroplanes already operating around the world, the Tecnam Research & Development team in Capua, Italy made extensive market research to establish what pilots wanted next from a Tecnam P92.

Tecnam discovered that many pilots were seeking out a new aeroplane with a tail wheel configuration. The Tecnam P92 Tail Dragger is born.

The Tecnam P92 Tail Dragger is the first new 'tail wheel' aeroplane available to the General Aviation community in quite a while. Consumers clearly indicated that they wanted a tail wheel aeroplane constructed from metal rather than fabric. They wanted their passenger to sit right next to them, rather than behind as in most legacy 'tail wheel' aeroplanes.

Tecnam's P92 Tail Dragger has been designed to offer many more functions including as a perfect towing airplane. It's also a great cargo carrier and is available with an optional, very large underside cargo pod, designed with two separate hinged doors. Customers can also opt for a 'classic' plane look, with not only several chrome plated components but also with modern and stylish lines and accessories with standard D-10 and even an iPhone holder.

Finally, for those pilots who prefer a Lycoming engine, the YO233 can be installed still offering more than 215kg payload.

TECNAM can offer now whatever you prefer.... make your flying fun, make your choice. The all new 6th generation Tecnam P92, the 'Tail Dragger'

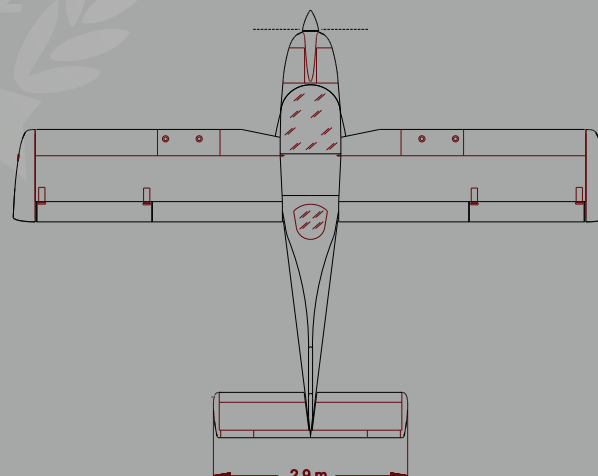
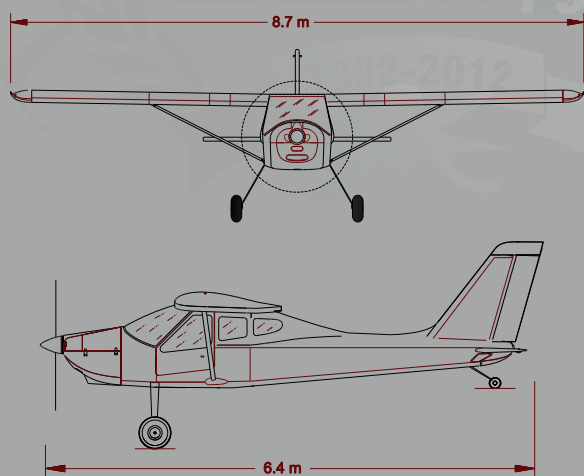

## ADVANCED ULTRA LIGHT

Aviation Home

Old Rayyan Street P.O.Box : 831, Doha-Qatar

Tel No: +974 4480 1665 Fax No: +974 4480 7577

info@aviationhomeqatar.com

sales@aviationhomeqatar.com

SPECIFICATIONS	P92 TD-ROTAX	P92 TD-LY
<b>ENGINE</b>		
Manufacturer	ROTAX	LYCOMING
Model	912 ULS	YO-233-B2A
Power	98 hp	115 hp
Number of Cylinders	4	
<b>PROPELLER</b>		
Manufacturer	GT PROPELLER	
Model	GT2	
Number of Blades	2	
Type	FIX PITCH - WOOD	
<b>DESIGN WEIGHT &amp; LOADING</b>		
MTOW	600 kg 1320 lb	
Standard Equip. Empty Weight	345 kg 760 lb	387 kg 850 lb
Standard Equip. Useful Weight	255 kg 560 lb	213 kg 470 lb
Baggage Allowance	20 kg 44 lb	
Limits Loads	+6 / -3 G	
<b>DIMENSION</b>		
Fuselage Height	2,5 m	8,2 ft
Fuselage Length	6,4 m	21 ft
Wing Span	8,7 m	28,5 ft
Wing Area	12,4 sqm	133 sqft
Cabin Width SEAT TO COVER	1,14 m	45 in
Cabin Height	0,91 m	3 ft
Fuel Tank Capacity	45 X2 lt	11,2 X2 GAL
<b>PERFORMANCE</b>		
	15°C SEA LEVEL 600 KG / 1320 LB	
VMAX	220 km/h	120 KTS
Cruise Speed 75%	220 km/h	118 KTS
VNE	270 km/h	146 KTS
Stall Speed FLAPS DOWN POWER OFF	76 km/h 41 KTS	78 km/h 42 KTS
Practical Ceiling	4572 m 15000 ft	
Takeoff Run	93 m 305 ft	90 m 295 ft
Takeoff Distance	270 m 885 ft	250 m 820 ft
Landing Run	130 m	426 ft
Landing Distance	250 m 820 ft	
Rate of Climb	5,6m/sec 1100 ft/min	6,1 m/sec 1200 ft/min
Range	493 N.M.	460 N.M.

www.aviationhomeqatar.com